



Champion Gas Hot Plate Stepped Series

Models: GHPS-2H GHPS-4H GHPS-6H

PRODUCT:

QUANTITY:

ITEM #:

Designed Smart

Increased Performance in Cooking

- Champion high output gas burners generate more than 36% more BTU's than competitive hot plates (30,000 BTU's per burner).
- Reduces amount of labor time to boil water by 50%.
- Fast start-up to prime cooking temperatures.
- Stepped back row allows operator to quickly access all burners and conveniently reach pans and large pots.
- Openings in the front allow the pilot light to be easily lit and adjusted without removing the front panel.

Safety Features

- New bull-nose front extension protects employees from burns.

Saves Time and Clean-Up Labor Cost

- Maintenance is easier with bottom-mounted grease collection pan and removable top grates.
- Field convertible and adjustable gas regulator.

Built Solid

Built to Last!

- Thick, stainless steel construction on front panel and top skirt protects against kitchen "wear and tear" and rust.
- Thick cast iron grates stand up to years of high output use.
- Welded construction.

Reliability backed by APW Wyott's Warranty

- APW Wyott cooking equipment is backed by a 3-year limited warranty, and a 1-year on-site labor warranty.
- Certified by the following agencies:



*Warranty does not include cooking grates or fireboxes



Model GHPS-4H Stepped Gas Hot Plate

APW Wyott Design Features

- Heavy-duty stainless steel and aluminized steel construction
- 30,000 BTU/hr per cast iron burner
- Smooth action, infinitely adjustable gas valves turn 180 degrees, giving the operator ultimate control.
- Field convertible and adjustable gas regulator
- Removable cast-iron grate
- Stainless steel collection pans
- Adjustable viewable pilot
- 4" (10 cm) adjustable legs
- Front or top-servicing
- High altitude versions available (contact factory)

Options & Accessories

- WOK Ring Accessory - Part # 21815507

See reverse side for product specifications.



APW Wyott Foodservice Equipment Company · 729 Third Ave., Dallas, TX 75226
(800) 527-2100 · (214) 421-7366 · Fax (214) 565-0976 · www.apwwyott.com · info@apwwyott.com

Rev. 1/23/2006

PRODUCT:

QUANTITY:

ITEM #:

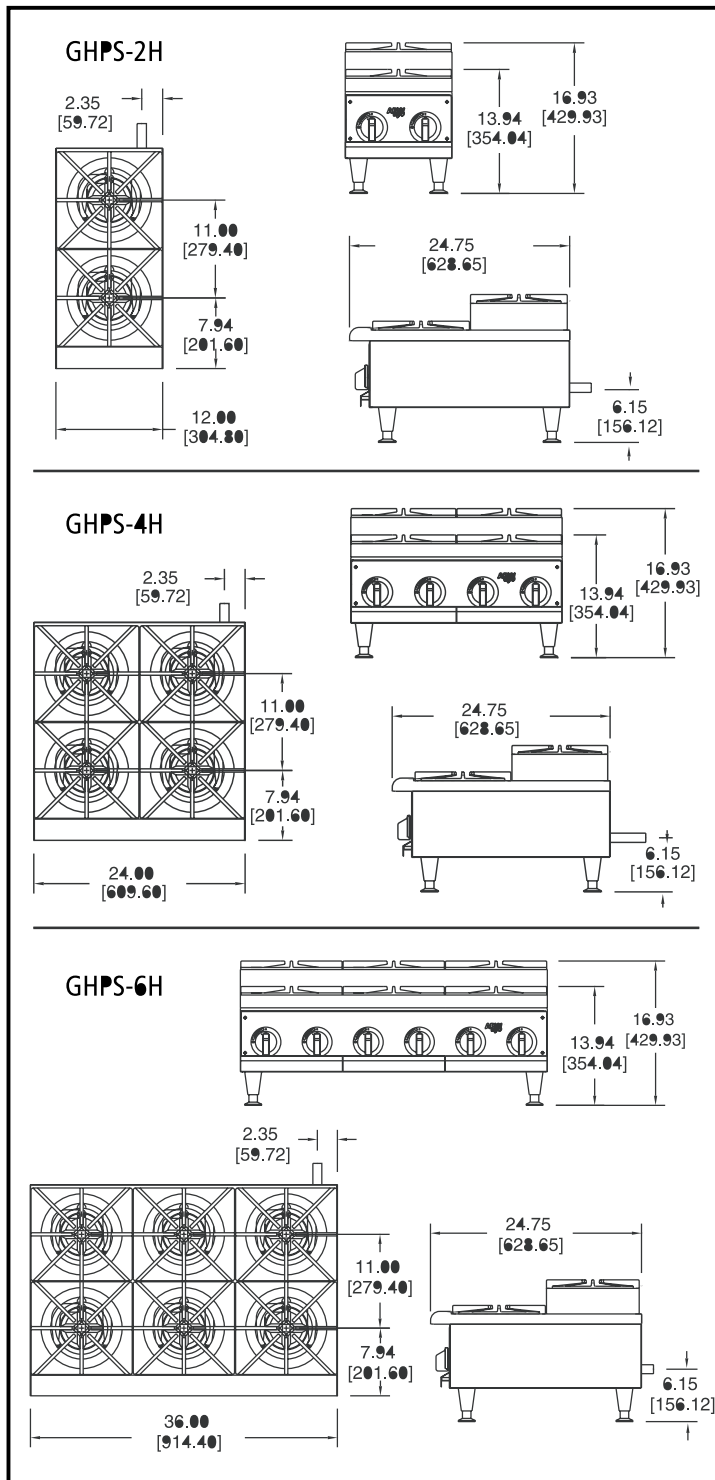

PRODUCT SPECIFICATIONS

Construction:

Stainless steel top skirt, crumb tray and front panel. Aluminized steel sides and back panel. Welded construction. Field convertible and adjustable gas regulator. 4" adjustable legs.

Gas Specifications:

GHPS-2H: 2 burners, 30,000 BTU/hr. each, total

GHPS-4H: 4 burners, 30,000 BTU/hr. each, total
120,000 BTU/hr. input

4 manual infinitely adjustable controls
(Propane is 120,000 BTU/hr.)

GHPS-6H: 6 burners, 30,000 BTU/hr. each, total
180,000 BTU/hr. input

6 manual infinitely adjustable controls
(Propane is 180,000 BTU/hr.)

Overall Dimensions:

GHPS-2H: 16 3/4" H x 12" W x 24 3/4" D
(42.5 cm x 30.5 cm x 63 cm)

GHPS-4H: 16 3/4" H x 24" W x 24 3/4" D
(42.5 cm x 61 cm x 63 cm)

GHPS-6H: 16 3/4" H x 36" W x 24 3/4" D
(42.5 cm x 91.4 cm x 63 cm)

Note: Regulator and pipe add 1 1/4" to the rear of the unit.

Shipping:

GHPS-2H: 55 lbs. (25 kg)

GHPS-4H: 108 lbs. (49.1 kg)

GHPS-6H: 188 lbs. (85 kg)

Freight Class: 85

FOB: Cheyenne, WY

*APW Wyott reserves the right to modify specifications or discontinue models without incurring obligation.